

Installation, Operation and Maintenance Instructions

Model 45HB-70HB

Multi-Stage Centrifugal Booster Pump



General Information

Models 45HB and 70HB are multi-stage, high-pressure, general-purpose centrifugal booster pumps, using enclosed impellers. Applicable for clear, non-hazardous liquids in general industrial services up to 180°F (82°C). Particularly suited for high-pressure booster services.

All models are close-coupled to electric motors containing prelubricated bearings designed for continuous service. Threaded shaft extension is protected by a stainless steel sleeve/coupling combination.

All models are equipped with single, unbalanced mechanical shaft seals.

Units are shipped completely assembled and ready for installation.

Important

1. Inspect unit for shipping damage.
2. Read all instructions carefully.
3. ALWAYS disconnect all electrical power when handling pump, motor, or controls.
4. Do not run unit dry or against a closed discharge. This will result in damage to mechanical seal and pump.
5. Never pump hazardous liquids or solvents.
6. Maximum liquid temperature: 180°F (82°C).
7. Maximum inlet pressure: 100 PSI.

Installation

Location: Locate pump as near the liquid source as practical. Allow adequate room for servicing and ventilation. Protect the unit from cold weather freezing and water damage due to rain or flooding. Pump may be mounted horizontal; or vertical with motor on top provided a drip-shield is used for motor protection.

Foundation: Foundation surface must be flat so there is no distortion and/or strain developed when tightening the foundation bolts. **CAUTION:** Bolting and/or piping must not put strain on liquid end. The pumps are quiet and smooth running, but rubber mounting is recommended on foundations susceptible to sound effect.

Alignment: No filed alignment is necessary as pumps are close-coupled.

Piping: Suction pipe must be at least equal in size to suction connection of pump and provide positive suction head (intake pressure) to the pump. Avoid using the pump for applications requiring suction lift. Never use a gate valve in the suction line to throttle the pump. **CAUTION:** Piping must not put strain on the liquid end.

Wiring: Electrical power supply must be a separate branch circuit equipped with proper starters, fuses or circuit breakers, wire size, etc., conforming to National Electrical Code plus local codes. Power supply voltage, phase and controls must match motor nameplate requirements. Low voltage and phase-loss (3 phase) protection is recommended.

Motors: Single-phase 3 HP motors are dual voltage 115/230 volts, 60 Hz, A.C. Single-phase 5 HP motors are 230 volts, 60 Hz, A.C. All other motors are three-phase, dual voltage 230/460 volts, 60 Hz, A.C. The higher voltages are recommended where available.

Rotation: Three-phase rotation must be checked at installation by momentarily energizing the completely filled pump and observing the rotation. Rotation is clockwise looking into the motor shaft, end-bell side (remove protective cap to observe shaft). Rotation must correspond to rotation arrow. Rotation of three-phase units can be reversed by interchanging any two (2) electrical power leads. **CAUTION:** Do Not run in reverse rotation or damage will result.

Operation

Fill suction line and pump with liquid to be pumped to insure mechanical seal will not run dry. With pump and suction line completely filled, and motor properly wired, the unit may be started. Be sure pump is not started against a closed valve in the discharge line.

Maintenance

1. Lubrication

Pumps should require no maintenance other than the motor bearings: In hot or severe service, lubricate every 3 months. Follow motor manufacturer's instructions to determine lubrication schedule. Lubricate with power off and motor warm. Remove upper and lower plugs at both bearing. Free lower relief hole of hard grease. Install clean grease-fitting on upper hole and add grease with a low-pressure grease gun. Run motor 30 minutes. Stop motor and remove drained grease. Replace all plugs.

CAUTION: Do Not over-grease.

Disassembly

1. Turn off all electrical power.
2. Drain system.
3. Disconnect piping.
4. Remove bolts holding motor to foundation.
5. Remove shaft snap ring (1) within discharge head (2).
6. Use a torch on both ends of casing to break-down thread sealant at casing threads.
7. Use wrenches on suction housing (21) and discharge head (2) to unscrew (counter-clockwise) discharge head and casing. Casing is threaded inside each end and sealed with thread sealant. The casing may come off with the discharge head or stay on the suction housing. If the casing remains on the suction housing it may be removed with a strap wrench. **CAUTION:** Do Not use a pipe wrench on the casing or damage will result. The unbroken thread sealant may be removed by applying heat with a torch.
8. Remove shaft sleeve (4) from shaft.
9. Stages, each consisting of a bowl, impeller, and diffuser, can now be removed.
10. Remove motor end-plug to expose slot in end of motor shaft.
11. Heat shaft sleeve/coupling with a torch by directing a flame through hole in suction housing (21). This will break down Loctite® thread locking compound to allow removal of the sleeve/coupling. Note: Thread is right-hand. Turn counter-clockwise to loosen.
12. Remove shaft assembly, including rotating portion of mechanical seal, by holding motor shaft with a screwdriver in motor shaft slot while turning pump shaft assembly counter-clockwise with a ½" wrench. Note: Due to the applied heat, the mechanical seal must be discarded and replaced with a new mechanical seal.
13. Remove bolts holding adapter to motor.
14. Remove suction housing/adapter combination from motor.
15. Place suction housing/adapter on a flat surface and push out stationary portion of mechanical seal.

Reassembly

1. Clean all parts, especially pump and motor register fits, seal seat counter bore in suction housing, and shaft (in particular where shaft sleeve/coupling fits against shaft shoulder).
2. Clean shaft sleeve/coupling threads and motor shaft threads. Clean old Loctite from threads with a wire brush. Apply Locquic Primer T®, (Loctite® Product No. 74756 available in Automotive Parts and Hardware stores) and allow to dry.
3. Lubricate counterbore of suction housing (21) and rubber bushing of new stationary seal seat with light oil or soapy water and press into counterbore squarely and evenly. **CAUTION:** Do Not mar or contaminate the lapped face of the new mechanical seal seat.
4. With motor in vertical position, remount suction housing/adapter on motor. Make certain the motor shaft does not dislocate the new mechanical seal stationary seat.
5. Apply a thin coat of light oil or soapy water to outer surface of sleeve/coupling and inside diameter of rubber portion of the new rotating seal member.
6. Slide spring retainer, spring and rotating member of the new mechanical seal over the sleeve/coupling, making certain the seal face stays in the holding collar, and spring retainer is squarely seated against shoulder of sleeve/coupling. **CAUTION:** Take care to prevent damage or dirt on lapped faces of the new mechanical seal.
7. Coat motor shaft threads with Loctite® 271.
8. Thread the shaft sleeve/coupling, with rotating portion of mechanical seal in place, onto the threaded motor shaft until the sleeve/coupling bottoms on the motor shaft shoulder. Use screwdriver in motor shaft slot to hold while tightening the shaft assembly with a ½" wrench.
9. Use a straight edge across face of suction housing to check location of outboard end of shaft sleeve/coupling. Due to variations in motor shaft lengths and pump parts, it will be from 0.080" short (below the straight edge) to flush.
10. If sleeve/coupling is below the straight edge, add 0.010" shims until top face of shims are one (1) shim higher than straight edge (interferes with straight edge).
11. Reassemble stages on shaft, checking impeller hub height after each stage. Hub must be flush with straight edge or higher. Add 0.010" shims as necessary.
- 11a. On 10 HP models install bearing spider at half way point in the stack, use shaft sleeve (13) and shim accordingly.
12. Install shaft sleeve (4) on shaft.
13. Apply thread sealant (Loctite® HVV Pipe Sealant) to suction housing (21) threads plus discharge head (2) threads and reassemble casing to pump. (Tighten to 50 foot pounds torque.) **CAUTION:** Do Not apply sealant to casing threads.
14. Turn pump by hand with a ½" socket over the end of the pump shaft inside the discharge head (2). Turn counter-clockwise. Unit should turn with resistance of only the mechanical shaft seal.
- 14a. Replace snap ring (1) on shaft.
15. Replace motor end plug.
16. Do not start unit until suction line and pump are completely filled with water. Refer to OPERATION Section.

Repair Parts

Item No.	Part Name	Pattern No.
1	Retaining ring	
2	Discharge head assembly – 2" NPT	57209
3	Marine bearing – Discharge head	
4	Sleeve – Discharge head	
5	Diffuser	
6	Impeller	
7	Bowl	
8	Shim	
9	Casing	
10*	Shaft/coupling assembly	
11	Intermediate stage assembly	57203
12	Marine bearing – Intermediate stage	
13	Sleeve – Intermediate stage	
14	Coupling	

Part No.	Part Name	Pattern No.
15	Washer (coupling screw)	
16	Mechanical screw	
17	Retaining ring	
18	Shaft sleeve	
19	Spring retainer	
20	Mechanical seal assembly	
21	Suction housing – 2" NPT	59098
22	Motor adapter (210 frame) Motor adapter (140-180 frame)	59153 59099
23	Hex cap screw – adapter to motor	
24	Hex cap screw – adapter to suction housing	

* Note: Shaft assembly includes screw (16) and washer (15).

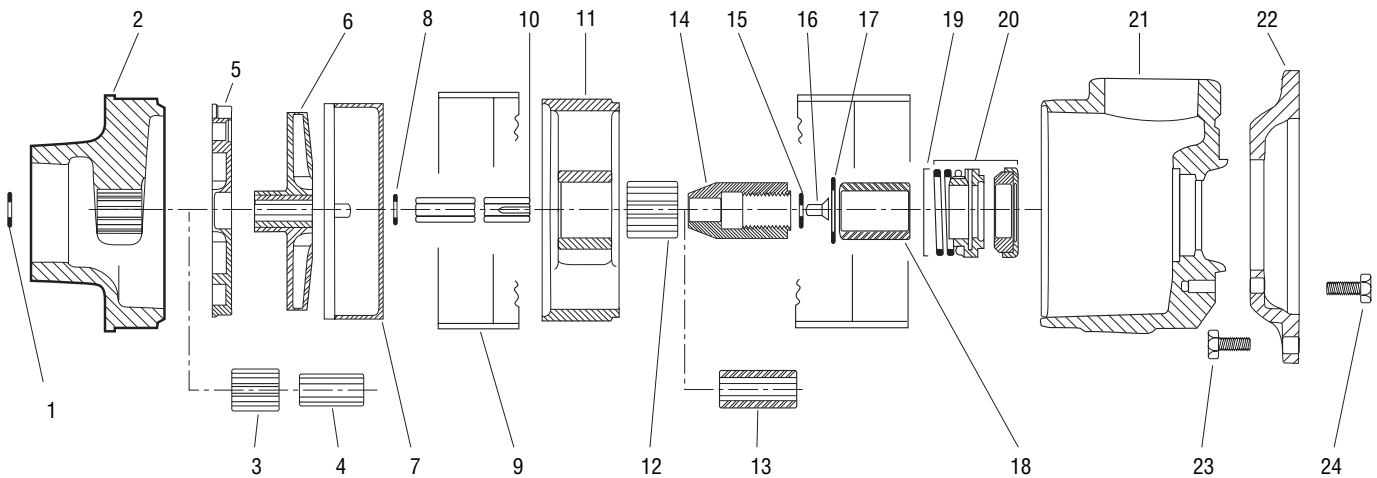

GOULDS PUMPS LIMITED WARRANTY

This warranty applies to all water systems pumps manufactured by Goulds Pumps.

Any part or parts found to be defective within the warranty period shall be replaced at no charge to the dealer during the warranty period. The warranty period shall exist for a period of twelve (12) months from date of installation or eighteen (18) months from date of manufacture, whichever period is shorter.

A dealer who believes that a warranty claim exists must contact the authorized Goulds Pumps distributor from whom the pump was purchased and furnish complete details regarding the claim. The distributor is authorized to adjust any warranty claims utilizing the Goulds Pumps Customer Service Department.

The warranty excludes:

- (a) Labor, transportation and related costs incurred by the dealer;
- (b) Reinstallation costs of repaired equipment;
- (c) Reinstallation costs of replacement equipment;
- (d) Consequential damages of any kind; and,
- (e) Reimbursement for loss caused by interruption of service.

For purposes of this warranty, the following terms have these definitions:

- (1) "Distributor" means any individual, partnership, corporation, association, or other legal relationship that stands between Goulds Pumps and the dealer in purchases, consignments or contracts for sale of the subject pumps.
- (2) "Dealer" means any individual, partnership, corporation, association, or other legal relationship which engages in the business of selling or leasing pumps to customers.
- (3) "Customer" means any entity who buys or leases the subject pumps from a dealer. The "customer" may mean an individual, partnership, corporation, limited liability company, association or other legal entity which may engage in any type of business.

THIS WARRANTY EXTENDS TO THE DEALER ONLY.

Goulds Pumps

